

Experiment No. 1:

Object: To find the low resistance by Carey Foster's bridge.

Apparatus Required: Carey Foster's bridge, decimal resistance box, laclanche cell, galvanometer, thick copper strip, plug key, rheostat of nearly 10 ohm, given wire and connecting wires.

Description of the Apparatus: The Carey Foster's bridge is as in the fig. One meter long wire EF of manganin or constantan of uniform cross-section area is stretched along a meter scale. The wire is connected at both the ends with copper strips. Beside these strips there is one copper strip B fixed parallel to the meter scale and two L-shaped strips A and C at the ends of the scale. In between these strips there are four empty spaces ab, cd, ef and gh. In one empty space ab, known resistance X, in second empty space cd a resistance P, in third empty space of a resistance Q and in fourth empty space gh the known resistance Y are connected. The leclanche cell E and plug key K are connected in between A and C. Between the points B and D, galvanometer G is connected. At point D, contact key is fixed which can move here and there on the wire EF. This key is known as jockey. On pressing jockey, point D gets connected with the galvanometer otherwise not.

Formula Used:

1) Resistance per unit length of the wire of bridge $\rho = X / (l_2 - l_1)$ ohm/cm.

Where l_1 = balancing length on the bridge wire measured from the left end when known resistance X is connected in left gap of the bridge and zero resistance is connected in right gap of the bridge and l_2 = balancing length of the bridge wire measured from the left end on interchanging the positions of X and Y.

2) Unknown resistance of the given wire $Y = X \frac{(l_2 - l_1)}{(l_1 - l_2)}$

where X = unknown resistance connected in the left gap, Y = resistance of the wire connected in the left gap, l_1 and l_2 respectively are the balancing lengths of the bridge wire measured from the left end, before and after interchanging the positions of X and Y

Figure:

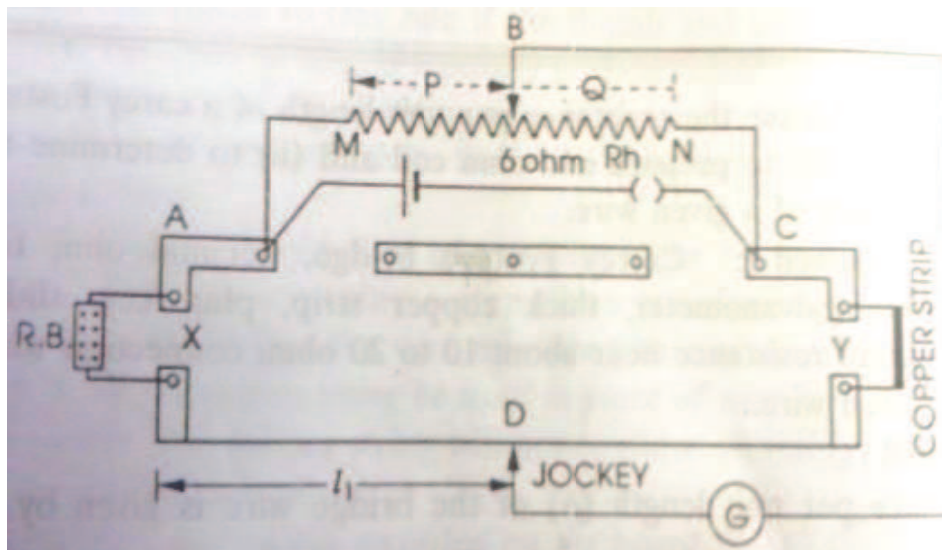

Procedure:

1) To determine the resistance per unit length of the bridge wire:

i) First the circuit is connected as in the fig. for which decimal resistance box X is connected in the left gap ab and copper strip Y is connected in the right gap of the bridge. Now both the lower fixed ends of the rheostat are connected to terminals A and C respectively and its variable end is connected to terminal B. Thereafter the leclanche cell E and the plug key K are joined in series in between the terminals B, its other end is connected to the jockey D.

ii) The variable end of the rheostat is adjusted in middle such that both the resistances P and Q are nearly equal.

iii) Now inserting some resistance X through the resistance box, the jockey D is pressed on the bridge wire and it is slid on it until zero deflection is obtained in the galvanometer. In this position, the distance l_1 of jockey from left end on wire is noted.

iv) Thereafter the positions of resistance box X and copper strip Y are interchanged and then without changing the resistance box, again the position of jockey is adjusted on the bridge wire in order to obtain zero deflection in the galvanometer. In this position, the length l_2 of the jockey on the wire from the left end is noted.

v) Now the experiment is repeated three – four times by changing the resistance X from the resistance box and each time the values of l_1 and l_2 are noted corresponding to the value of X.

vi) Then using the relationship $\rho = X / (l_2 - l_1)$, the value of ρ is calculated for each observation and its mean value is calculated.

2) To determine the resistance of a given wire:

i) To determine the resistance of a given wire, from the electric circuit as in the fig. The copper strip connected in the left is withdrawn and in its place the given wire is connected.

ii) The above steps 2, 3, 4 and 5 in part (i) of the experiment are repeated.

iii) Now using the relation $Y = X - \rho (l_2 - l_1)$, the value of Y is calculated from each observation and its mean value is obtained.

Precaution:

(1) For greater sensitivity of the bridge, the resistance connected in the four gaps of the bridge should be nearly equal.

(2) Clean the ends of connecting wires with sand papers.

(3) Never allow the flow of current in the circuit for long duration otherwise resistance wire will get heated which in turn increase its resistance. For this, in the circuit insert the plug in key only while taking observations.

(4) Do not move the jockey on the meter bridge wire by rubbing otherwise thickness of wire will not remain uniform.

(5) Initially shunt should be used while adjusting galvanometer, but near zero deflection position, it must be removed.

(6) Only that resistance plug should be removed from the resistance box for which zero deflection is observed in the middle of the bridge wire. In this state sensitivity of the bridge is maximum and percentage error is minimum.

(7) Except the resistance removed in the R.B box, all other plugs should be firmly tight.

(8) Before pressing the jockey on the bridge wire, plug should be inserted in the plug key attached with the cell so that electric circuit gets completed before the galvanometer gets connected in the circuit.

Result

1. Resistance per unit length of the Carey- Foster’s bridge wire = ... ohm/cm

2. Resistance of the given wire = ... ohm

Viva – Voce

Q1 What is your experiment?

Q2. Why are you using the Carey Foster’s bridge instead of Meter Bridge?

Q3 Which apparatus are you using to determine the resistance of the wire in your experiment?

Figure:

Observations:

1. To determine the resistance per unit length of the bridge wire:

S.No	Resistance connected in resistance box X (in ohm)	Zero deflec. Position when resistance box is connected		(l_2-l_1) (in cms)	$\rho = X/ (l_2-l_1)$ (in ohms)
		In left gap l_1 (in cms)	In right gap l_2 (in cms)		

2. For the given resistance wire:

S.No	Resistance connected in resistance box X (in ohm)	Zero deflec. Position when resistance box is connected		(l_2-l_1) (in cms)	$Y = X- (l_2-l_1)$ (in ohms)
		In left gap l_1 (in cms)	In right gap l_2 (in cms)		
1					
2					

2

Mean Y =Ohms

Calculations:

(1) For resistance per unit length of bridge wire :

For first observation , $\rho = \dots$

For second observation $\rho = \dots\dots\dots$

Mean $\rho = \dots$ ohm/cm

(2). For the resistance of the given wire:

For first observation $Y = X- \rho (l_2-l_1) = \dots\dots\dots$

MeanY= ohm



Experiment No: 2

Object: To measure high resistance by substitution method.

Apparatus Used: A high resistance sensitive galvanometer (G), A high resistance box of about $0.5\text{M}\Omega$ in steps of $0.1\text{M}\Omega$, unknown high resistance (X) of value greater than R (may be of the order of $1\text{M}\Omega$), A suitable resistance box to act as shunt (S) of galvanometer, battery(6-8 volt), one-way key (K), two 2-way key (ab and ac)

Formula Used: As in the fig. this method, first high resistance, X, is connected to the battery through galvanometer and deflection, θ_1 is obtained. Current through galvanometer is

$$I_g = E / X + G = K\theta_1 \dots\dots\dots (1)$$

Then X is disconnected and resistance box R is connected. A suitable value of R is introduced and shunt, S, is now used to obtain deflection, θ_2 in the galvanometer which is nearly equal or equal to θ_1 . Current now is

$$I_g' = E/R + SG/S+G .S/(S+G) = K \theta_2 \dots\dots\dots (2)$$

Dividing eq. (1) by (2) , we get

$$X = [R(G+S)/S + G] \theta_2 / \theta_1 - G \dots\dots\dots (3)$$

Note if $\theta_1 = \theta_2$, relation reduces to

$$X = R(C+S) / S \dots\dots\dots (4)$$

Procedure:

1. To find galvanometer resistance:

Put in plug between a and b and note the deflection, θ , in the galvanometer. It should be fairly large. Then insert key, K, and adjust the shunt, S, such as to reduce the deflection to half of its previous value θ . Then value of S is the galvanometer resistance.

2. To find unknown high resistance:

- (i) Connect a and b to bring unknown resistance into the circuit. Note deflection θ_1 in the galvanometer.
- (ii) Now open a and b and connect a and c to bring known resistance, R into the circuit. With suitable value of R adjust shunt, S in order to make deflection, θ_2 in the galvanometer nearly equal to deflection θ_1 .
- (iii) Increase R in steps of $0.1\text{M}\Omega$ and repeat the observations.

Figure:

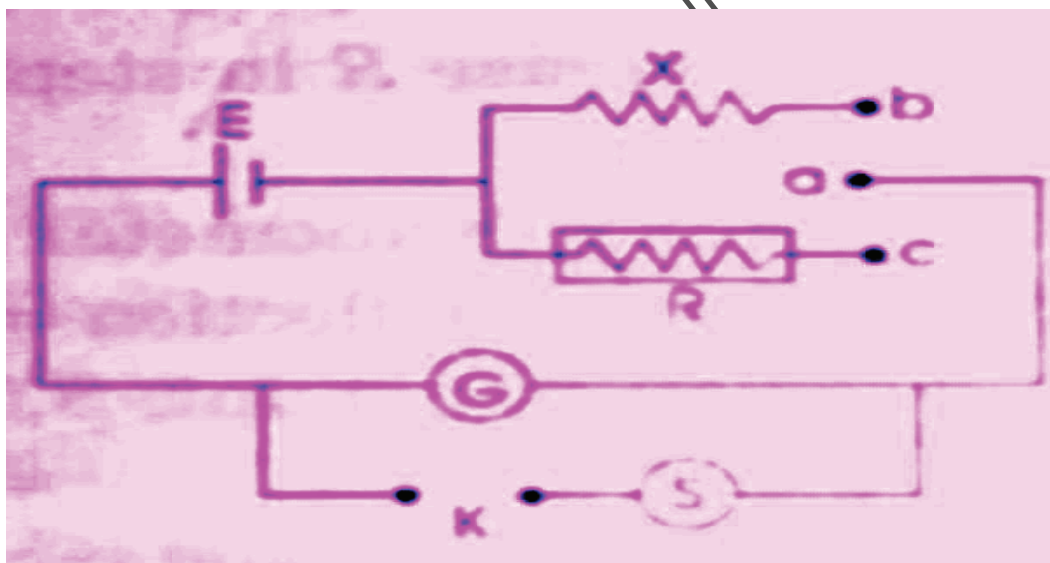

Observations:

1 For galvanometer resistance, G: Initial Deflection =

Value of shunt, S, to reduce deflection to half of its value =ohm

For high resistance, X =

No.	Deflection with		R ohms	S ohms	Calculated value of X	Mean value of X ohms.
	X, θ_1	R, θ_2				
1
2

Result: Value of unknown resistance, X =ohms

Calculations:

Use the relation: $X = [R(G+S)/S + G] \theta_2 / \theta_1 - G = \dots$ ohms

For each set and then take mean.

Sources of Error and Precautions:

(i) A sensitive galvanometer should be used.

(ii) Value of shunt, S, should be measured with accuracy. It is better to use a standard (SWG) copper wire along with resistance box to get nearly equal values of deflection in the two cases.

(iii) The method is an approximate one. For suitable setup it is desirable to have a rough idea of the value of unknown resistance before hand.

Experiment no. - 3

Object: To determine high resistance by the method of leakage of a condenser.

Apparatus Used: Ballistic Galvanometer, accumulator, Morse key, two way key, standard Condenser (capacity of the order of 1.0 or 0.5 μ .F), given resistor, stop watch and connection wires.

Formula Used:

The high resistance R is given by

$$R = t / 2.3026 C \log_{10} \theta_0 / \theta_1$$

Where t = time period of the leakage of condenser through the resistance.

θ_0 = first throw of spot of light when initially the condenser is discharged through ballistic galvanometer.

θ_1 = first throw of spot of light when the condenser is discharged through the ballistic galvanometer after a leakage of charge for time t through R.

C = capacity of the standard condenser.

Procedure:

- (i) Make the electrical connections as in the fig.
- (ii) Close K1(ii) and press the Morse key, i.e. charge the condenser for 40 seconds.
- (iii) Release the Morse key K2 so that the condenser is discharged through the galvanometer. Note down the first throw θ_0 .
- (iv) Repeat the procedure of the points (ii) and (iii) several times, i.e. every time charge condenser and then discharge through B.G. Obtain mean value of θ_0
- (v) Closing K1 (ii) and pressing Morse key K2, charge the condenser for the same time. Keeping Morse key pressed, open K1 (ii) and close K1(i). Start the stop watch.
- (vi) After a measured time t seconds, (say 5 or 10 sec.) release Morse key and note down the first throw θ_t in the galvanometer.
- (vii) Repeat procedure (v) and (vi) for different values of t.

Figure:

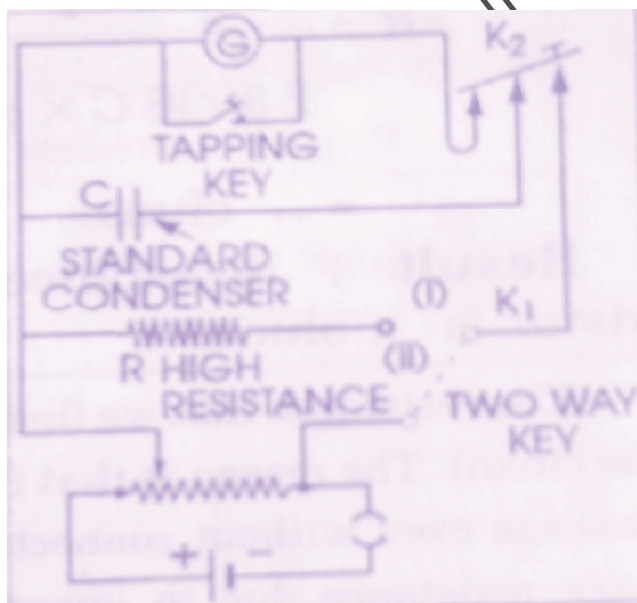

Observation:

S.No	Throw in Galvanometer	Mean θ_0	Leakage time t sec	Throw in B.G. θ_t	θ_0 / θ_t	$\log_{10} \theta_0 / \theta_t$
1
2

Calculations:

Plot a graph with t on X-axis and $\log_{10} \theta_0 / \theta_t$ on Y-axis. From this graph obtain the slope as shown in figure.

The slope of the curve = $\log_{10} \theta_0 / \theta_t / t$

Value of C (given) = $\mu\text{F} = \dots \times 10^{-6}$ Farad

Therefore * $R = t / 2.3026 C \times \log_{10} \theta_0 / \theta_t / t = \dots$ ohms.

To calculate Rleak:

The procedure is same as adopted in the measurement of R except that the high resistance is never put in the circuit.

(i) First charge the condenser for same time and then open key K_1 .

(ii) Allow the condenser to stand for specific time (say t seconds) which should be measured by a stop watch.

(iii) After this specific time, release the Morse key and note down the deflection θ_t' of light spot on the scale due to passage of remaining charge of the condenser through the ballistic galvanometer. Thus t' is the time for which the condenser is allowed to leak through itself and θ_t' is the first throw of the galvanometer corresponding to the charge left on condenser after leakage for time t' .

(iv) Repeat this process for different intervals of time for the condenser to leak through itself and note corresponding throws of the galvanometer.

(v) Since each time condenser in charge for the same time θ_0 will remain the same as taken in the experiment of determining R .

Result: Resistance of the given resistor isohms.

Sources of Error and Precautions:

(i) The galvanometer coil should be made properly free.

(ii) Tapping key should be used across the galvanometer.

(iii) Condenser should be free from dielectric loss.

(iv) After observing θ_0 , the galvanometer coil should be at rest for observing the value of θ_t .

(v) Thus true value of high resistance can be calculated by above formula. R has been calculated previously.

VIVA VOCE

1. What do you leak in order to determine high resistance?
2. What is the time constant of R - C circuit?
3. Why do you say that it is method of determining high resistance?
4. What is the order of resistance you determine?

Experiment No 4:

Object: Measurement of e/m by helical method.

Apparatus Used: A cathode ray tube, a solenoid of proper dimension, in the interior of which a **cathode** ray can be placed; A control which contains under it a power supply and controls (a) to operate the tube (b) to operate the solenoid (c) to provide variable a.c.voltage for deflection Plates; An ammeter range (range d.c. one ampere); Voltmeter (range 1.5 k-volts); One commutator.

Figure:

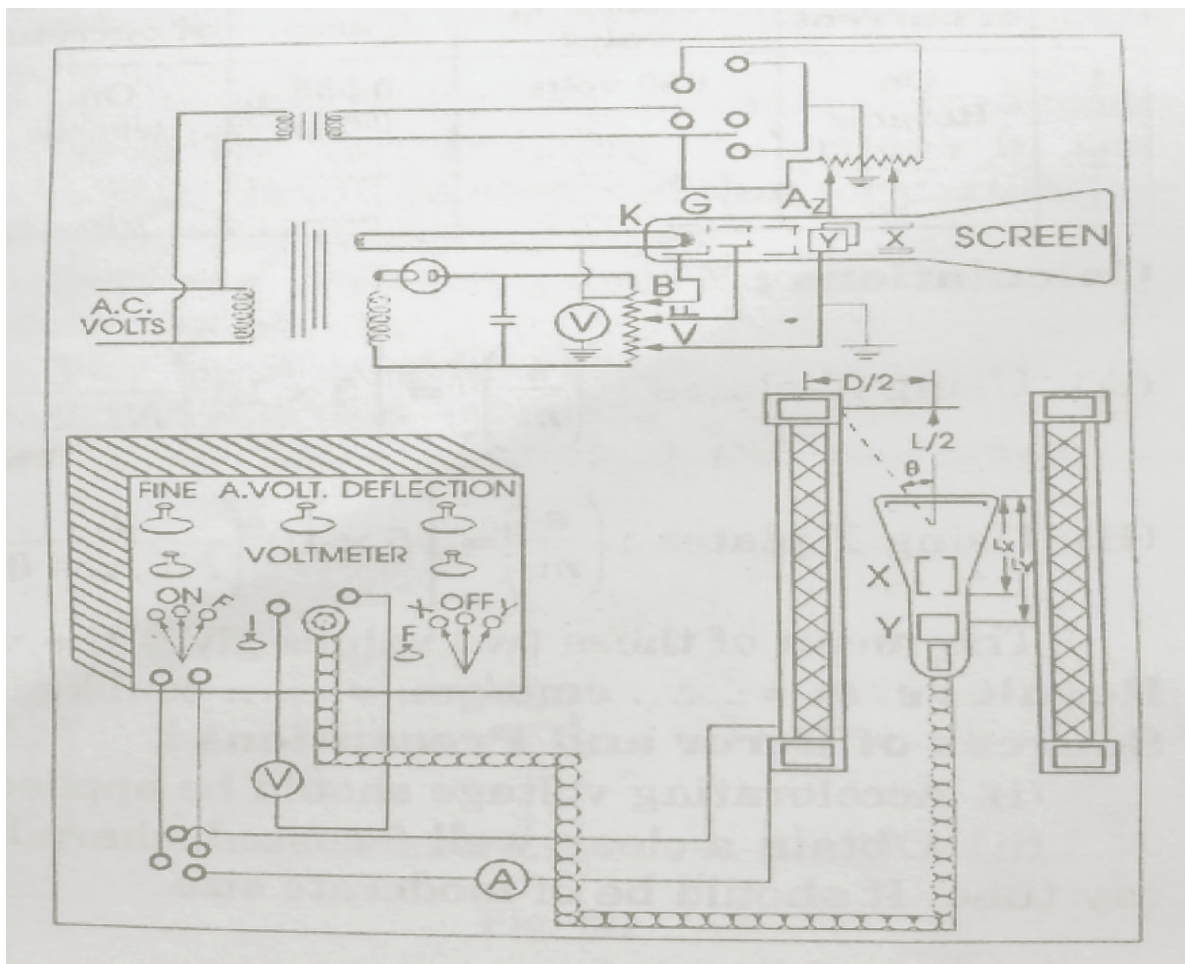

Procedure:

- (i) Record the constants of the solenoid and tube.
- (ii) Place the solenoid such that its axis lies in the east west direction. Mount the cathode ray tube inside the solenoid at the centre. The power unit should be kept as far away as possible to avoid the stray magnetic field.
- (iii) Switch on the power supply unit. Turn the potentiometer marked "Accelerating Voltage" and adjust the voltage, V , to any desired value.

With the help of F and I make a fine and clear spot on the cathode ray tube.

(iv) Apply a.c deflecting potential to one set of plates, say X-plates. A deflection of 2 cm. is adequate for the experiment.

Now turn on the solenoid current and increase the current till the line is reduced to a small point. Reverse the solenoid current and readjust the control to a fine point. The average of these two currents in amperes is I.

(v) Repeat procedures of point (iv) above with Y-plates. Keep deflection 2cm. Find I.

(vi) Now repeat the whole procedure from point (iii) to (iv) with three other values of accelerating voltages. It will be necessary to refocus the spot in the tube at each voltage.

Result: $e/m = \dots \text{emu/gm.} = \dots \text{coul/kg.}$

Observations:

- (A) 1. Distance between the edge of X-plate and the screen $l_x, = \dots \text{cm.}$
- 2. Distance between the edge of Y-plate and the screen $l_y, = \dots \text{cm.}$
- 3. Diameter of the solenoid $D, = \dots \text{cm.}$
- 4. Length of the winding $L, = \dots \text{cm.}$
- 5. Number of turns, $N = \dots \text{cm.}$
- 6. $\cos \theta = L / \sqrt{(L^2 + D^2)} = \dots$

(B)

S.No	Using X Plates			Using Y Plates		
	Direction of Current	Accelerating Voltage V, volts	Current I amp.	Direction of current	Accelerating Voltage V volts	Current I amp.
1						
2
3

Calculations:

(A) **Using X-plates:** $(e/m)_x = [5 \times 10^9 (L / N l_x \cos \theta)^2] V / I^2 \text{ e.m.u./gm.}$

(B) **Using Y-plates:** $(e/m) = [5 \times 10^9 (L / N l_y \cos \theta)^2] V / I^2 \text{ e.m.u./gm.}$

The mean of these two values gives the value of e/m.

Sources of Error and Precautions:

- (i) Accelerating voltage should be applied carefully.
- (ii) Obtain a clear, well focused, sharp line on screen of cathode ray tube. It should be of moderate size.

Experiment No 5:

Object: To determine the ionization potential of the gas filled thyatron.

Apparatus: A thyatron tube 884, two grid bias supplies (0-30 V), two voltmeters (0- 30 V), a micro ammeter (or a sensitive galvanometer), two rheostats.

Procedure:

- (i) Make the electrical connections as in the fig.
- (ii) Keep both the grid and the plate at zero potential. There will be some deflection in the μA on heating the filament. To reduce it to zero, apply just necessary negative potential to the plate (keeping grid at zero potential). Keep this plate voltage constant throughout the experiment.
- (iii) Now apply positive potential to the grid. Increase it gradually in small steps and corresponding deflections in the micro ammeter (or galvanometer). It will be observed that for particular value of grid, deflection increases very much.
- (iv) Draw a graph between deflection (on Y-axis) and grid potential (on X-axis) as in fig.
- (v) From the curve, the value of grid voltage corresponding to steep rise of micro ammeter deflection (showing plate current) is calculated. This gives the ionization potential; of the gas filled in thyatron.

Figure :

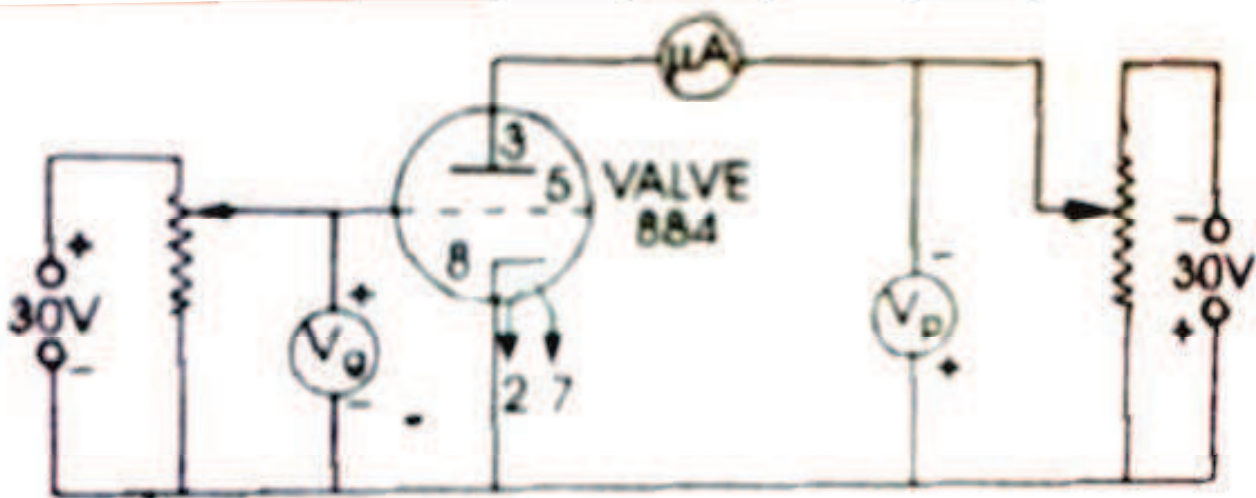

(vi) Remove the micro ammeter from the plate circuit and connect it in the grid circuit as in the fig.

(vii) Keeping the same plate potential (fixed in the point (ii)), give negative potential to the grid just to reduce any deflection in μA to zero. Note down this value which will be subtracted from the calculated value of ionization potential to find the correct value of the latter.

Result:

Ionization potential of the gas filled in thyatron valve = value from graph-velocity correction = volts.

Standard Value =volts

Percentage Error =

Sources of Error and Precautions:

- (i) Micro ammeter or galvanometer used in the experiment should be very much sensitive.
- (ii) Velocity correction should be determined carefully.

Observations:

(A) Readings for ionization Potential:

Plate Potential =volts.

(B) Velocity Correction:

Grid voltage =volts

Calculations:

Plot the graph in grid voltage and corresponding deflection in micro ammeter. Find the value of ionization potential.

VIVA VOCE

1. What do you mean by ionization potential?
2. Of what substance are you finding the ionization potential?
3. What is gas in the thyatron valve?
4. What is a thyatron valve?
5. What is their construction?

Experiment No 6:

Object: To plot graph showing the variation of magnetic field with distance along the axis of a circular coil carrying current and to estimate from it the radius of the coil

Apparatus Required: tangent galvanometer of the Stewart and Gee type, a strong battery, a rheostat, a commutator, plug key and connective wires.

Formula Used:

The field F along the axis of a coil is given by

$$F = \frac{2 \pi n r^2 i}{10 (x^2 + r^2)^{3/2}}$$

Where n = number of turns in the coil

r = radius of the coils

i = current in ampere flowing in the coil

x = distance of the point from the centre of the coil.

If F is made perpendicular to H earth's horizontal field, the deflection θ of the needle is given by:

$$F = H \tan \theta$$

Thus

$$F = \frac{2 \pi n r^2 i}{10 (x^2 + r^2)^{3/2}} = H \tan \theta$$

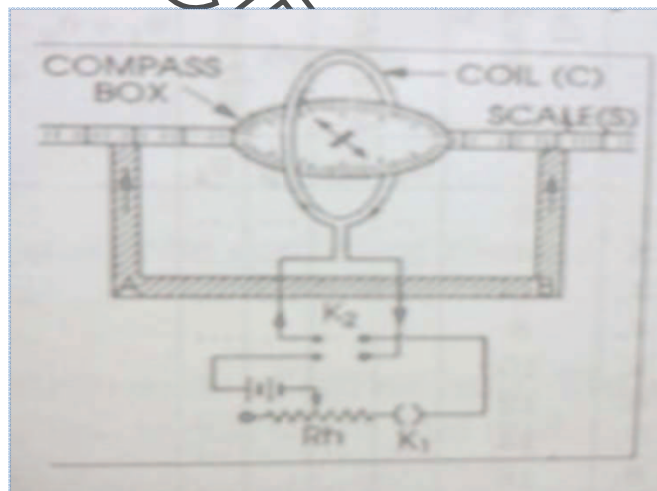

Procedure:

- (i) Place the magnetometer compass box on the sliding bench so that its magnetic needle is at the centre of the coil. By rotating the whole apparatus in the horizontal plane, set the coil in the magnetic meridian roughly. In this case the coil, needle and its image all lies in the same vertical plane. Rotate the compass box till the pointer ends read 0-0 on the circular scale.
- (ii) To set the coil exactly in the magnetic meridian set up the electrical connections as in the fig. Send the current in one direction with the help of commutator and note down the deflection of the needle. Now reverse the direction of the current and again note down the deflection. If the deflections are equal then the coil is in magnetic meridian otherwise turn the apparatus a little, adjust pointer ends to read 0-0 till these deflections become equal.

(iii) Using rheostat R_h adjust the current such that the deflections of nearly 70° to 75° is produced in the compass needle placed at the centre of the coil. Read both the ends of the pointer. Reverse the direction of the current and again read both the ends of the pointer.

The mean of four readings will give the mean deflection at $x = 0$.

(iv) Now shift the compass needle through 2cm. each time along the axis of the coil and for each position note down the mean

deflection. Continue this process till the compass box reaches the end of the bench.

(v) Repeat the measurements exactly in the same manner on the either side of the coil.

(vi) Plot a graph taking x along the axis and $\tan \theta$ along the y-axis.

(vii) Mark the points of inflexion on the curve. The distance between the two points will be the radius of the coil.

Observation:

S.no	Distance of needle from the centre x	Deflection on East arm					Deflection in West arm				
		Current one way		Mean	in degree	tan	Current one way		Mean	in degree	Tan
		θ_1	θ_2				θ_3	θ_4			
1	2										
2	4										
3	6										
4	8										
5	10										
6	12										
7	14										
8	16										

Result: The graph shows the variation of the magnetic field along the axis of a circular coil carrying current. The distance between the points of inflexion P, Q and hence the radius of the coil = ...cms.

Precautions and Sources of Error:

- (i) The coil should be carefully adjusted in the magnetic meridian.
- (ii) All the magnetic materials and current carrying conductors should be at a considerable distances from the apparatus.
- (iii) The current passed in the coil should be of such a value as to produce a deflection of nearly 75° .
- (iv) Current should be checked from time to time and for this purpose am ammeter should be connected in series with the battery.
- (v) Parallax should be removed while reading the position of the pointer. Both ends of the pointer should be read.
- (vi) The curve should be drawn smoothly.

VIVA VOCE

1. What is the direction of the field?
2. Is the field uniform at the centre?
3. How can you get wider region of uniform field?
4. Is it true for any direction of current in the two coils?
5. If any current carrying conductor is placed close to the coil then will it effect your measurement?

EXPERIMENT NO. 7:

Object: To study the variation of the thermo electric e.m.f. with temperature, for a copper-iron thermocouple, by means of a potentiometer and to determine (i) the neutral temperature, (ii) melting point of naphthalene.

Apparatus Used: Potentiometer(coil type or 10 wire), standard cadmium cell, battery, a copper iron thermocouple, high resistance box, high resistance rheostat, one way key, two way and connection wires.

Formula Used:

The thermo electric e.m.f. (e) developed in a thermocouple is obtained with the help of the following formula:

$$e = \rho El / R$$

Where ρ = resistance per unit length of the potentiometer wire,

E = resistance taken out from the resistance box (resistance across which the standard cell is balanced)

L = length of the potentiometer wire when thermo e.m.f. is balanced.

Procedure:

(i) The electric connections are made as shown in fig. 2 The rheostat R_h should be of high value and a resistance of 1,018 ohms is taken out from the resistance box.

(ii) Now jockey is placed at the point A and the key K_1 and K_2 (i) are closed. The value of the rheostats R_h is so adjusted that there is no deflection in the galvanometer. In this way the e.m.f. of standard cell is balanced by the potential difference across the R.B. This is known as standardization of the potentiometer wire.

(iii) Open K_2 (i) and connect K_2 (ii) so that the thermocouple is in circuit. When the temperature of the hot junction has become steady, press the jockey on the wire by adjusting the length of the potentiometer wire so that again a balance point is observed. Note the length (l) of the potentiometer wire from A to balancing point.

(iv) Repeat the above procedure and determine the balancing lengths of the potentiometer wire at various decreasing temperatures of the hot junction.

(v) Calculate the value of e.m.f generated using the formula used.

(vi) Plot the graph between the temperature differences of two junctions as abscissae and the corresponding thermo e.m.f.'s, as ordinates. The curve is of the shape as shown in figure.

(vii) In order to determine the melting point of naphthalene, we take the naphthalene in a tube. This tube is placed in a water bath for heating. The hot junction of the thermocouple is placed in naphthalene. When two-third of naphthalene melts, the balance point is obtained on the potentiometer. Note down the balancing length. Now calculate the e.m.f. corresponding to this length. With the help of the graph determine the corresponding temperature. This temperature will be the melting point of naphthalene.

Figure:

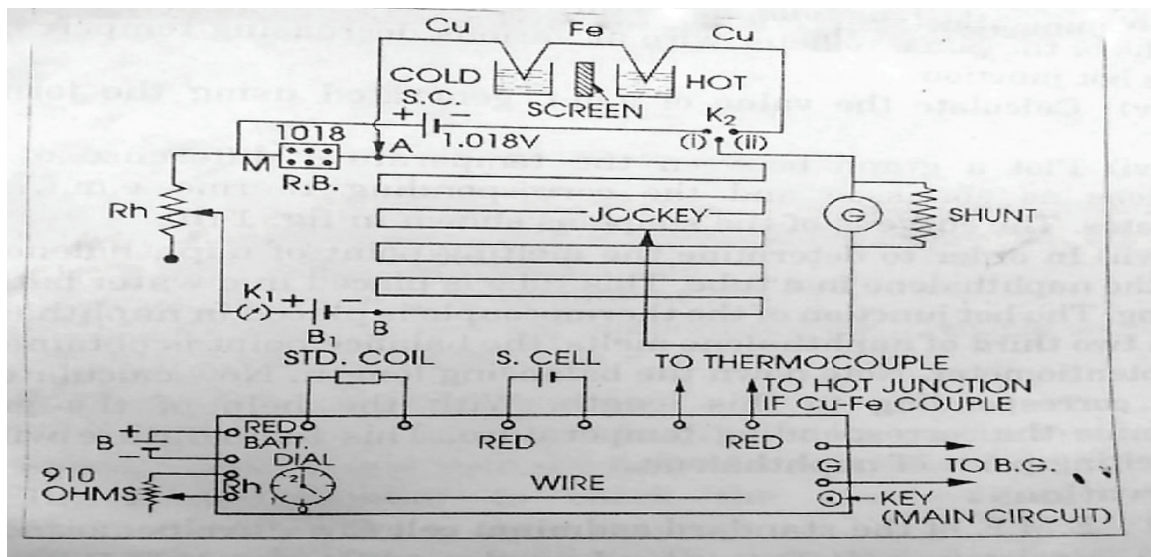

Observations:

- (i) E.M.F. of the standard cadmium cell $E = \dots$ volts
- (ii) Resistance, introduced in the resistance box R.B. = \dots ohms
- (iii) Resistance per unit length of the potentiometer wire (ρ) = \dots ohm/cm
- (iv) **Table for the determination of thermo e.m.f.'s with temperature.**
Room Temperature = \dots oC
- (v) Balancing length when naphthalene melts = \dots cm

Calculations:

- (i) At \dots oC, $e = E \rho l / R = \dots$ micro volts
- (ii) At \dots oC, $e = E \rho l / R = \dots$ micro volts

Similarly calculate for other temperatures.

Result:

- (i) The variation of thermo e.m.f. of the copper iron thermocouple with temperature is shown in the graph
Neutral temp. from graph = \dots oC
- (ii) Melting point of naphthalene = \dots oC

Standard Result: The neutral temperature for \dots couple = \dots oC.
Melting point of naphthalene = \dots oC

Precautions and Sources of Error:

- (i) If the resistance per unit length ρ of the potentiometer wire is not known, determine with the help of a post office box.
- (ii) It is essential to check the standardization of the potentiometer after two or three readings.
- (iii) The ends of connections wires should be properly cleaned.
- (iv) The battery employed in this experiment should be fully charged.
- (v) The jockey should be pressed gently and momentarily.
- (vi) The galvanometer employed in this experiment should be a sensitive one and it should be shunted in the initial stages of locating the null point.
- (vii) The temperature of the hot junction should be recorded at the time of taking the balance reading of potentiometer.

VIVA VOCE

1. What is thermocouple?
2. What is thermo-electric effect?
3. On what factors does the direction of thermoelectric current depend?
4. What is neutral temperature?
5. Is it same for every thermocouple?
6. What is temperature of inversion?
7. Is it same for every couple?
8. What is their value for Cu-Fe thermocouple?
9. What are the values of thermo e.m.f. for the following couples? Antimony-bismuth couple, Copper-constantan couple and Copper-iron.
10. What is Peltier Effect?
11. What is Thomson Effect?

Experiment No 8:

Object: To determine the value of Planck's constant h by a photo cell.

Apparatus Used: Vacuum type photo-emissive cell mounted in a wooden box provided with a wide slit, optical bench with uprights, D.C. power supply, resistance box. Rheostat, a set of filters, ballistic galvanometer, tapping key, lamp and scale arrangements and connection wires.

Formula Used: The value of Planck's constant h is given by: $h = e (V_2 - V_1) \lambda_1 \lambda_2 / c(\lambda_1 - \lambda_2)$

Where e = electronic charge, V_2 = stopping potential, V_1 = stopping potential, c = velocity of light.

Procedure:

- (i) The electrical connections are made.
- (ii) The lamp and scale arrangements are adjusted to get a well focused spot on the zero mark of the scale. The photocell is mounted at one end of the optical bench. At the same level and nearly 60-80 cm. from the photocell, a light source is arranged. The light is allowed to fall on the cathode of photocell. Now a suitable filter of known wavelength is placed in the path of ray reaching to photocell.
- (iii) A deflection is observed in ballistic galvanometer. i.e. the spot of light moves on the scale. If the spot moves out of the scale, then it is adjusted on the scale with the help of rheostat R connected in series of ballistic galvanometer. This deflection corresponds to zero anode potential as key K_1 is open.
- (iv) A small negative potential is applied on the anode by closing key k_1 and adjusting the rheostat R_h . This voltage is recorded with the help of voltmeter. The corresponding galvanometer deflection is noted by noting the deflection of spot on the scale.
- (v) The negative anode potential is gradually increased in small steps and each time corresponding deflection is noted till the galvanometer deflection is reduced to zero.
- (vi) The experiment is repeated after replacing the green filter in succession by two filters e.g. blue and yellow.
- (vii) Taking negative anode potentials on X-axis and corresponding deflections on Y-axis, graphs are plotted for different filters.

Figure :

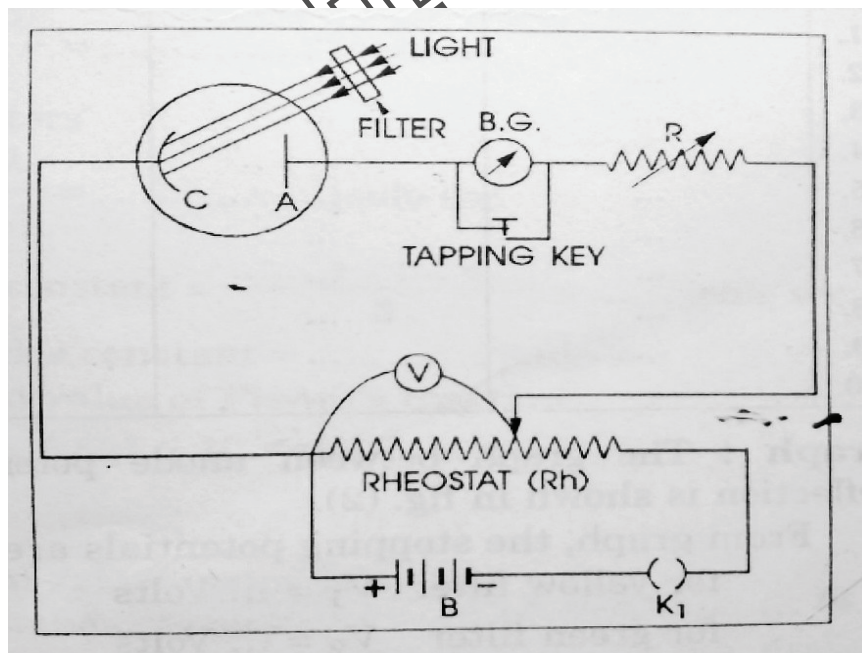

Observations:

S.No.	Negative anode potential in volts	Galvanometer deflection in cms		
		Yellow filter $\lambda_1 = \dots A^\circ$	Green Filter $\lambda_2 = \dots A^\circ$	Blue filter $\lambda_3 = \dots A^\circ$
1				
2				
3				
4				
5				

Graph: the graph between anode potentials and galvanometer deflection is shown in the fig.

From graph, the stopping potentials are:

For yellow filter $V_1 = \dots$ volts

For green filter $V_2 = \dots$ Volts

For blue filter $V_3 = \dots$ volts.

Calculations:

Electronic charge $e = 1.6 \times 10^{-19}$ coulombs

Speed of light $c = 3 \times 10^8$ m/sec.

Wavelength of yellow filter $\lambda_1 = \dots \text{Å} = \dots \text{m}$

Wavelength of green filter $\lambda_2 = \dots \text{Å} = \dots \text{m}$

Wavelength of blue filter $\lambda_3 = \dots \text{Å} = \dots \text{m}$

1. for yellow and green filters

$$h = e (V_2 - V_1) \lambda_1 \lambda_2 / c (\lambda_1 - \lambda_2) = \dots \text{joule-sec.}$$

2. for green and blue filters:

$$h = e (V_3 - V_2) \lambda_2 \lambda_3 / c (\lambda_2 - \lambda_3) = \dots \text{joule-sec.}$$

3. for yellow and blue filters:

$$h = e (V_3 - V_1) \lambda_1 \lambda_3 / c (\lambda_1 - \lambda_3) = \dots \text{joule-sec.}$$

Mean value of Planck's constant = $\dots + \dots + \dots / 3 = \dots \text{joule-sec.}$

Standard Value: Standard value of Planck's constant = 6.625×10^{-34} joule-sec

Percentage Error:

% error = $\text{experimental value} - \text{standard value} / \text{standard value} \times 100 = \dots \%$

Result: The value of Planck's constant = $\dots \text{Joules-sec.}$

Sources of Error and Precautions:

- (i) The experiment should be performed in a dark room to avoid any stray light to photocell.
- (ii) The observations should be taken by altering anode potential in small steps of 0.05 volts
- (iii) Corresponding to zero anode potential, the deflection of light spot on scale should be adjusted at its maximum value.
- (iv) Smooth graphs should be plotted.
- (v) Stopping potentials should be read carefully.
- (vi) The experiment should be performed at least with three filters.

Experiment no 9:

Object: To determine the self inductance of given coil by Rayleigh's method.

Apparatus Used: Post office box, ballistic galvanometer, stop watch, decimal ohm box, an accumulator, given inductance, rheostat (4 or 5 ohms.), tapping key, double key, a stretched resistance wire and connection wires.

Formula Used:

Self inductance (L) of the coil is given by:

$$L = r/\phi T/2\pi .\theta (1+\lambda/2)$$

Where r = small resistance (0.1 or 0.01 ohm) introduced in series with the inductance,

ϕ = steady deflection in ballistic galvanometer when r is introduced in the circuit,

T = time period of the coil of galvanometer,

θ = first throw of the galvanometer when inductance L is employed in the circuit,

λ = logarithmic decrement = $2.3026 \times 1/10 \log_{10} \theta_1 / \theta_{11}$

Where θ_1 and θ_{11} are first and eleventh observed throw of the galvanometer respectively.

Procedure:

(i) Set the galvanometer and lamp and scale arrangement such that the spot of light moves freely on both sides of zero of the scale.

(ii) Make the electrical connections as in the fig.

(iii) Fix the ration P: Q at 10:10. Pressing K1 and K2 adjust the resistance in R arm and the sliding contact on r' such that there is no deflection in the ballistic galvanometer. Here first of all the battery arm should be adjusted to have a near balance with the help of R and then rheostat r'. In this case the resistance, r in resistance box should be zero.

(iv) Keeping K1 and K2 pressed introduce a small resistance say 0.01ohm in the resistance box and obtain the steady deflection ϕ in the galvanometer.

(v) Repeat the above procedure for other small values of r and obtain the steady deflection ϕ in each case.

(vi) Keeping r = 0 again obtain the balance point. With K2 keeping pressed, break the cell circuit by releasing K1. Note down the first throw. Repeat this observation two or three times, each after checking steady balance.

(vii) Now to note θ_1 and θ_{11} first break cell circuit by releasing key, K1 and then immediately after it, release galvanometer key K2. the spot will oscillate on the scale. Measure θ_1 and θ_{11} . Repeat the process three or four times.

(viii) Now disconnect galvanometer from the bridge and by touching its connecting wires with mouth, make its coil oscillating. Note the time for different oscillations and then calculate the time period T of the galvanometer coil.

Figure:

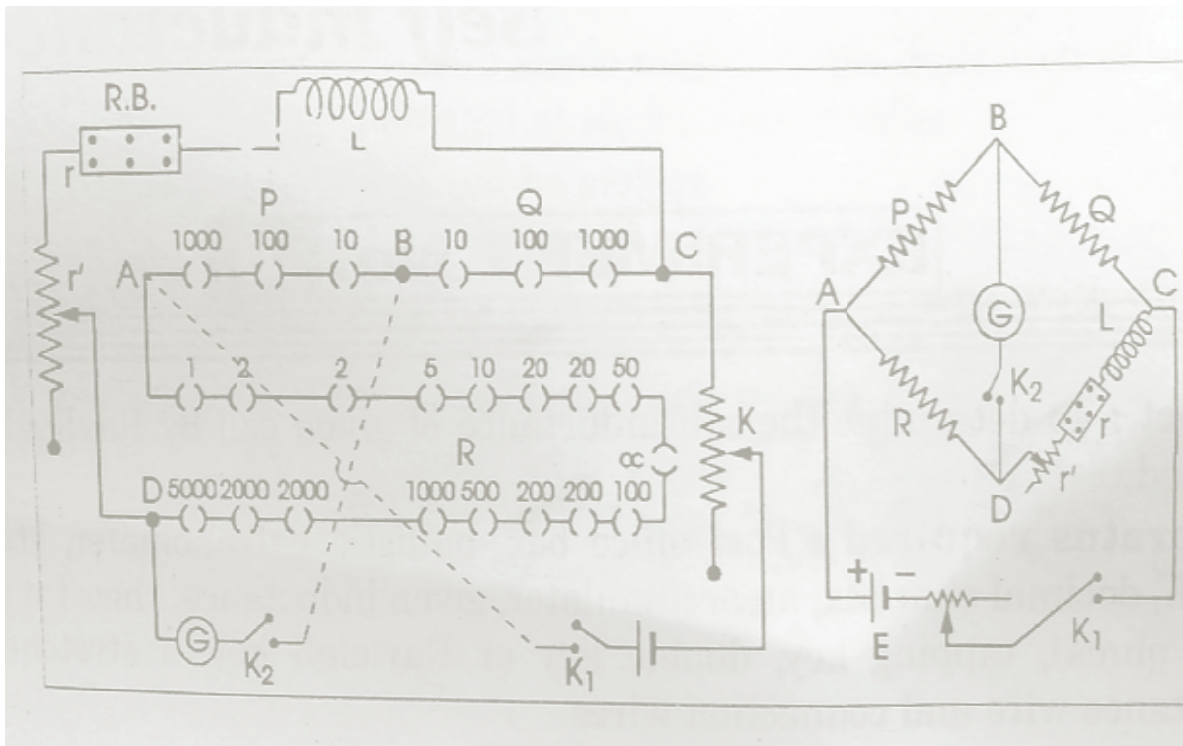

Observations

(1): Reading for the determination of θ and Φ

S.No.	Ballistic throw		Successive throws of galvanometer			Mean θ_1/θ_{11}	Determination of r/Φ			
	θ	Mean	θ_1	θ_{11}	θ_1/θ_{11}		r	Φ	r/Φ	Mean r/Φ
1										
2										
3										

(2) Reading for determination of the time period

S.no	No of oscillations	Time taken	Total secs.	Time period	Mean secs.
1	5				
2	10				
3	15				
4	20				

Calculations: $\lambda = 2.3026 \times 1/10 \log_{10} \theta_1/\theta_{11}$
 $L = r/\phi T/2\pi .\theta (1+\lambda/2) = \dots$ henrys.

Result: The self inductance of the coil $L = \dots$ henrys.

Precautions and Sources of Error:

- (i) The galvanometer coil should be freely moved in the space between the pole pieces.
- (ii) Tapping key should be connected across the galvanometer
- (iii) To get a suitable deflection in the galvanometer a high adjustable resistance should be connected in series with cell.
- (iv) All resistances used in the experiment should be non inductive.
- (v) To secure maximum sensitiveness of the bridge all the four arms of the bridge should have nearly equal resistance.
- (vi) The connection wires should be uncoiled.
- (vii) The resistance introduced in the resistance box should be very small so that it may not affect the value of the steady current in that branch appreciably.
- (viii) While determining the time period of the galvanometer, the galvanometer circuit should be kept open.
- (ix) Keys K1 and K2 may have to be released in quick succession by personal judgment. For better results a Raleigh key should be used.

VIVA VOCE

- 1 Define self inductance.
- 2 What is the unit of self inductance?
- 3 Define a Henry.
- 4 Why do you take inductance coil in the form of helix, and not as a straight conductor?
- 5 Upon what factors does the value of flux depend?
- 6 Why do you observe steady deflection by introducing a small resistance R in the circuit? Why not large resistance?
- 7 What type of connecting wires should be used and why?
- 8 Suppose L_1 and L_2 be the self inductance of the two circuits and k be coupling coefficient between them, then what is mutual inductance?

Experiment 10:

Object: To study hall effect in an N-type semiconductor. To determine (i) Hall voltage and Hall coefficient, (ii) the number of charge carriers per unit volume, (iii) Hall angle and mobility.

Apparatus Required: A rectangular slab of semiconductor crystal of thickness about 0.3 mm, electromagnet, and search coil, calibrated flux meter to measure magnet field or ballistic galvanometer, millivoltmeter, battery ammeter, keys.

Formula Used: As shown in the fig. d is the thickness along Z-axis of the crystal. Magnetic field, B , is also applied along Z-axis. Current, I_x , is made to flow along X-axis. Hall voltage V_H , is developed across the faces that are normal to Y-axis. L_x is the length of the crystal along X-axis. If permeability of the medium of the crystal is μ , then actual magnetic field within the crystal is $B_z = \mu B$.

(i) Hall voltage, V_H , is measured with the help of millivoltmeter.

(ii) Hall coefficient: $R_H = V_H / I_x \cdot d / B_z \cdot 10^4 \text{ met}^3/\text{coulomb}$

Where V_H is in volts, I_x is in amperes, d is in meters and B_z in gauss. If B_z is measured in weber/met² then $R_H = V_H / I_x \cdot d / B_z \text{ met}^3/\text{coulomb}$.

(iii) No. of charge carriers per unit volume in the semiconductor crystal, n , is given by:

$$n = -1/R_H \cdot e \text{ met}^3$$

Where $e = 1.6 \times 10^{-19} \text{ coul}$.

(iv) Hall angle: $\phi = V_H / V_x \cdot l_x / b \text{ rad}$.

Where l_x and b both are in meter.

(v) Mobility: $m\mu = \phi / B_z \text{ rad.met}^2 / \text{Weber}$.

Procedure:

1 Place the specimen in the magnetic field of the strong magnet and make other connections as in fig.

2 Allow some current, I_x , with the help of rheostat, R_h , to flow through the semiconductor crystal along X-axis. Measure Hall voltage, V_H , with the help of millivoltmeter and V_x by voltmeter.

3 Change value of I_x in steps by rheostat, R_h , and note corresponding values of V_H and I_x values. It will be a straight line whose slope will be given by V_H / I_x .

4 Measure magnetic field, B , with a gauss meter or flux meter and find the actual field in the crystal, $B_z = \mu B$.

Figure:

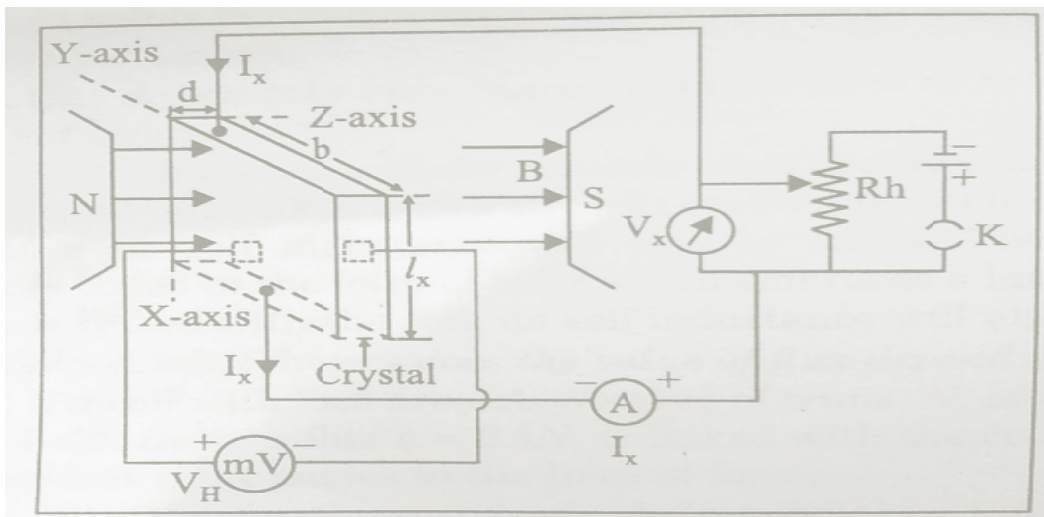

Observations:

- 1 Permeability of the specimen, $\mu = \dots\dots\dots$
 Magnetic field $B = \dots\dots\dots$ gauss or weber/met².
 Actual field in the crystal $B_z = \mu_B = \dots\dots$ gauss or weber/met².
- 2 Width of the crystal along Z-axis, $d = \dots\dots\dots$ met
 Width of the crystal along Y-axis, $b = \dots\dots\dots$ met
 Length of the crystal along X-axis, $l_x = \dots\dots\dots$ met
- 3 Measurement of Hall voltage:

Calculations:

- 1 A graph is plotted in V_H and I_x . From its slope $\tan \theta = V_H / I_x = BC/AB$ is found. Then Hall coefficient is $R_H = \tan \theta \cdot d/B_z \cdot 10^4 \text{ met}^3/\text{coul.} = \dots\dots\text{met}^3/\text{coul.}$
- 2 The number of charge carriers per unit volume $n = -1 / R_H \cdot e = \dots\dots\dots$
- 3 Hall angle, $\phi = V_H / V_x \cdot l_x/b = \dots\dots\text{rad.}$
- 4 Mobility, $m\mu = \phi/B_z = \dots\dots\dots\text{rad}\cdot\text{met}^2/\text{weber.}$

Result:

Hall coefficient, $R_H = \dots\dots\dots\text{met}^3/\text{coul}$
 No. of charge carriers, $n = \dots\dots\dots$
 Hall angle $\phi = \dots\dots\dots\text{rad.}$
 Mobility $m\mu = \text{rad}\cdot\text{met}^2/\text{weber.}$

Sources of Error and Precautions:

- 1 Hall voltage developed is very small and should be measured accurately with the help of a millivoltmeter or potentiometer.
- 2 Current through the crystal should be strictly within the permissible limits.

VIVA VOCE

- 1 What is Hall Effect?
- 2 On what factors the sign of Hall potential depends?
- 3 Illustrate the above questions 1 and 2.
- 4 How do you define Hall coefficient?
- 5 What is mobility?

Figure 1:

Graph:

Experiment no 11:

Object: To draw the characteristics of PN junction diode.

Apparatus Required: transistor, millimeter and micro ammeter, battery, rheostat, voltmeter and connection wires.

Procedure:

(A) Forward Biasing:

- (i) Connections are made as in the fig.
- (ii) With the help of rheostat, apply different voltages to the PN junction and note the corresponding reading of current in millimeters.
- (iii) Plot a graph in applied voltages and corresponding currents.

(B) Reverse Biasing:

- (i) Make the connections as in the fig. and proceed exactly in the same way as opted for forward biasing.

Figure:

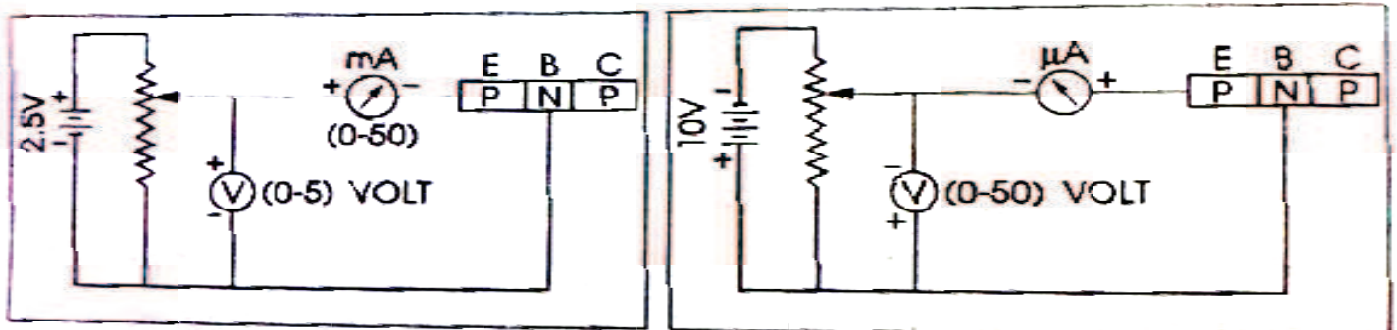

Observations:

S.No.	Forward Biasing		S.No.	Reverse Biasing	
	Voltage in volts	Current in mA		Voltage in volts	Current in mA
1	1
2	2
3			3		
4			4		
5			5		

Calculations: (Graph plotting):

Plot two graphs- one for forward and other for reverse biasing between voltages applied and the corresponding currents

Result: The characteristic of junction diode () are shown in the graphs.

Sources of Error and Precautions:

- (i) To avoid over heating of the transistor, current should not be passed for long durations.
- (ii) Voltages applied should be well below the safety limit of the transistor.
- (iii) Connections should be made carefully.

VIVA-VOCE:

1. What is a PN junction diode?
2. What do you mean by P-type germanium and N-type germanium?
3. What property PN junction exhibits?
4. What is the order of currents in the above two cases?
5. Mention the order of voltages with it.
6. What if high voltage is applied in forward bias?
7. Have you heard of turn over voltage?

Experiment No. 12:

Object: To determine the energy band gap of a semiconductor (germanium) using four probe method.

Apparatus Required: Probes arrangement (it should have four probes, coated with zinc at the tips. The probes should be equally spaced and must be in good electrical contact with the sample), Sample (germanium or silicon crystal chip with non-conducting base), Oven (for the variation of temperature of the crystal from room temperature to about 200°C), A constant current generator (open circuit voltage about 20 V, current range 0 to 10 mA), Millivoltmeter (range from 100mV to 3V, electronic is better.), power supply for oven, thermometer

Formula Used: The energy band gap, E_g , of semiconductor is given by $E_g = 2k \cdot 2.3026 \times \log_{10} \rho / 1/T$ (in K) in eV. Where K is Boltzmann constant equal to 8.6×10^{-5} eV/deg., and 'ρ' is the resistivity of the semiconductor crystal, given by $\rho = \rho_0 / f$ (W/s) Where $\rho_0 = V/I \times 2\pi s$. For function f (W/s) refer to the data table given in the calculations. S is the distance between the probes and W is the thickness of semi conducting crystal. V and I are the voltages and current across and through the crystal chip.

Procedure:

Connect one pair of probes to direct current source through milliammeter and other pair to millivoltmeter. Switch on the constant current source and adjust current I, to a desired value, say 2 mA. Place four probe arrangements in the oven. Fix the thermometer. Connect the oven power supply and start heating. Measure the inner probe voltage V, for various temperatures.

Figure:

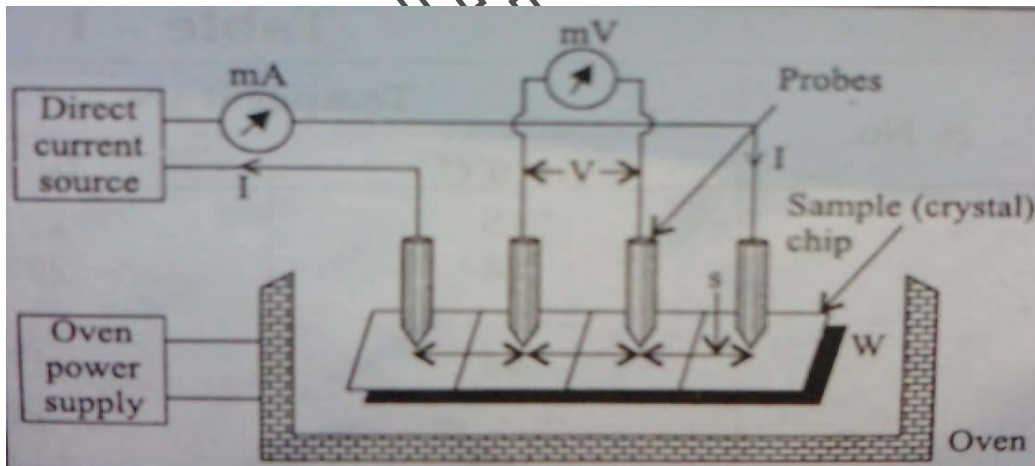

Observations:

- (i) Distance between probes (s) =mm
- (ii) Thickness of the crystal chip (W) =mm
- (iii) T and V for current (I) =mA(constant)

Table 1

S.No.	Temperature		Voltage V in volts
	In 0 C	in K	
1			
2			
3			
4			
5			
6			

Calculations:

First find resistivity, ρ , corresponding to temperatures in K using the relation: $\rho = \rho_0 / f(W/s)$, Where $\rho_0 = V / I \times 2\pi s = \dots \text{ohm.cm}$. Corresponding to different values of V, there will be different values of ρ_0 . Find them after putting for I and s from the table. Find W/s and then corresponding to this value of the function f (W/S) from the following table:

Values for Germanium crystal chip with nonconducting base:

Table 2

W/s	f(W/s)
0.100	13.863
0.141	9.704
0.200	6.931
0.333	4.153
0.500	2.780
1.000	1.504
1.414	1.223
2.000	1.094
3.333	1.0228
5.000	1.0070

If any W/s value is not found in the table then plot a graph in these (W/s) and f (W/s) values. From graph the desired value of f (W/s) corresponding to any value of resistivity, ρ , for various values of ρ_0 i.e. for various values of V which correspond to various values of temperature and tabulate as follows:

Table 3

Temperature T, in K	Resistivity, ρ ohms cm	$1/T \times 10^3$	$\log_{10} \rho$
291
297
.....

Finally plot a graph in $(1/T \times 10^3)$ and $\log_{10} \rho$ as in fig. Find the slope of the curve $AB/BC = \log_{10} \rho / (1 / T) \times 1000$. So the energy band gap of semiconductor (germanium) is given by:

$$\begin{aligned}
 E_g &= 2k \cdot 2.3026 \times \log_{10} \rho / 1/T \\
 &= 2k \times 2.3026 \times AB/BC \times 1000 \\
 &= 2 \times 8.6 \times 10^{-5} \times 2.3026 \times AB/BC \times 1000 \text{ eV} \\
 &= 0.396 \times AB/BC \text{ eV}
 \end{aligned}$$

Standard Result: $E_g = \dots\dots\dots \text{eV}$ for Germanium $E_{ggs} = 0.7 \text{ eV}$

Percentage Error: =

Result: energy band gap for semiconductor (....) is $E_g = \dots\dots\dots \text{eV}$

Sources of Error and Precautions:

- The resistivity of the material should be uniform in the area of measurement.
- The surface on which the probes rest should be flat with no surface leakage.
- The diameter of the contact between the metallic probes and the semiconductor crystal chip should be small compared to the distance between the probes

VIVA VOCE

- 1 What is energy and gap?
- 2 How do you differentiate between a conductor, an insulator and a semiconductor in relation to energy gap?
- 3 do you know about intrinsic and extrinsic semi-conductor?
- 4 why a semi-conductor behaves as an insulator at zero degree Kelvin?
- 5 What is the advantage of four probe method over other methods of measuring resistivity?

Experiment No 13:

Object: To determine the hysteresis loss by C.R.O.

Apparatus Required: A step down transformer, specimen transformer hysteresis loss of which is to be calculated, capacitor ($8\mu\text{F}$). Resistor ($50\text{ K}\Omega$ potentiometer), A.C Voltmeter ($0\text{-}10\text{ V}$), A.C milliammeter ($0\text{-}500\text{ mA}$), rheostat (10 ohm).

Formula Used:

Hysteresis loss per unit volume per cycle is given by: $W = i.V.\text{area of B-H loop} / f.\pi \text{ area of rectangle joules / cycle}$. Where i = current in primary winding in ampere, V = voltage across primary winding corresponding to i . $F = 50\text{c/s}$, Area can be counted in millimeter² from the centimeter graph of B-H loop. Count the small squares of mm.

Procedure:

- (i) Apply some voltage, V , with the help of rheostat, R_h . Connect XX plates and YY plates of C.R.O. keep frequency selector of CRO to external. Now adjust gain of the horizontal and vertical amplifiers of CRO to obtain a suitable B-H curve on the screen. To obtain a correct curve adjust value of R , also may interchange B-B terminals to Y-plates. Note voltage, V and current, i . Trace the curve on the trace paper. Note that once horizontal gain and vertical gain of amplifiers is selected, they are to be kept constant through out the experiment.
- (ii) Vary rheostat, R_h , to some other value. i.e. select new values of V and i . Trace the B-H curve on paper and write on it V and i values.
- (iii) Re-sketch all B-H curves with V and i values on a centimeter graph. Find the area in mm^2 required in the formula.

Figure :

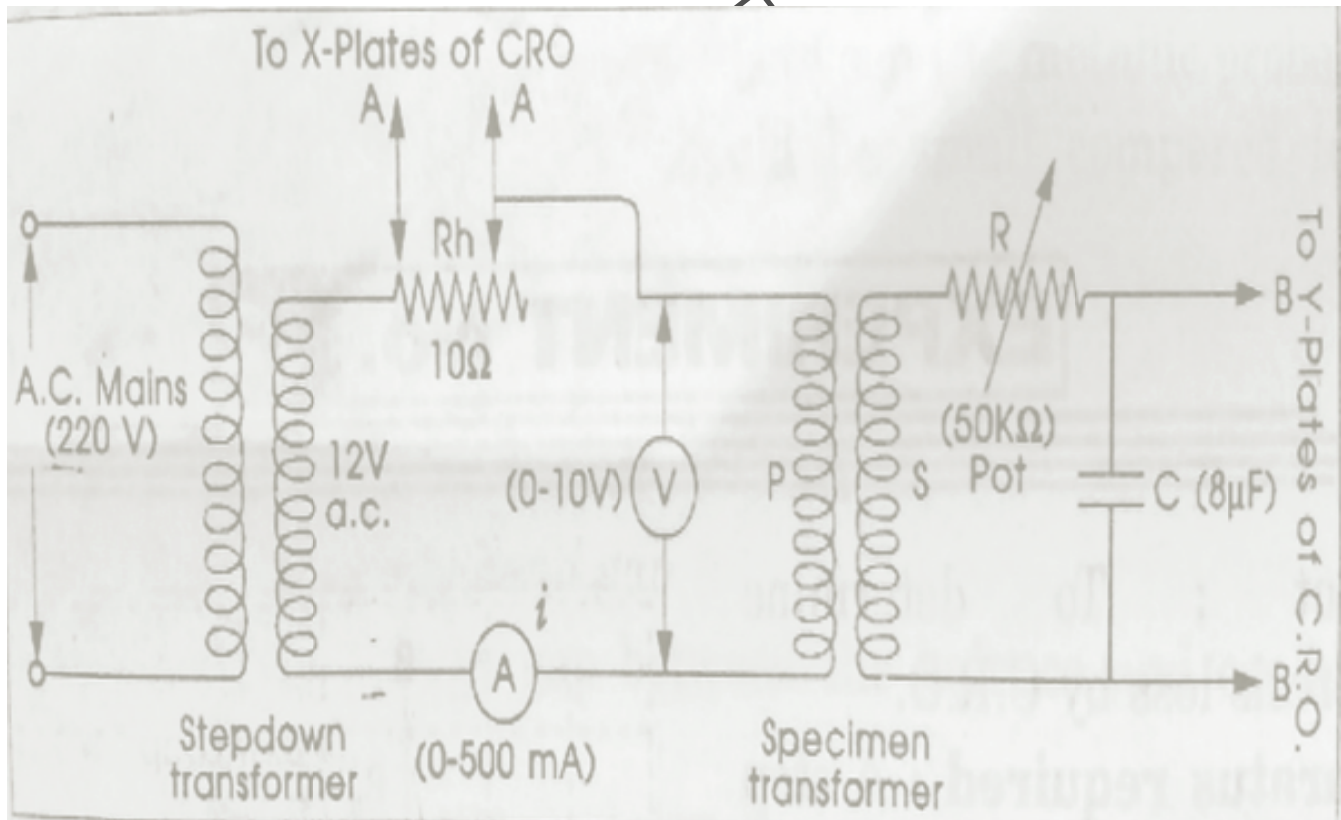

Observations:

S.no.	Current i, mA	Pot. diff. V, volts	Area of loop, mm ²	Area of rectangle, mm ²
1
2
3
4
5

Hysteresis loss per unit volume per cycle is given by

$$W = i.V \text{ Area of B-H loop} / f.\pi.\text{Area of rectangle} = \dots\dots\dots\text{joules/cycle}$$

Result: The hysteresis loss of the specimen transformer per unit volume per cycle isjoules/cycle.

Precautions:

- (i) Attenuator of C.R.O should be kept at a suitable position. The positions of X and Y amplifiers should not be disturbed after adjusting it once in the whole experiment.
- (ii) Variations in the supply voltage will affect the tracing of the curve on the paper.
- (iii) Handle C.R.O carefully.